

Congestion Management in Power Transmission Network Using TCSC

V.K.Deepthi¹, B. Baddu Naik²

Student, Dept. of EEE, PVPSIT, Vijayawada, Andhra Pradesh, India¹,
Asst.Professor, Dept. of EEE, PVPSIT, Vijayawada, Andhra Pradesh, India²

Abstract: Now a days, the electrical power system experiencing a new challenges and it has additional requirements for operation of power Systems. Transmission lines are often driven close to or even beyond their thermal limits in order to satisfy the increased electric power consumption and trades due increase of the unplanned power exchanges. If exchanges were not controlled, some lines on particular buses, may become overloled, this phenomenon is called congestion. One of the Most challenging problems in the operation of power system is congestion management. FACTS devices as an efficient and powerful Key role in Transmission congestion management. In this paper, TCSC has been used for congestion mangement in the transmission network. This method is applied on IEEE 14 bus system and simulation results was sucessfully tested using MATLAB-SIMULINK

Keywords: Thyristor Controlled series Capacitor (TCSC), over loading, Loss sensitivity index, Active, reactive power flow.

1.INTRODUCTION

As power systems are becoming more complex it requires careful design of the new devices for the operation of controlling the power flow in transmission system, which should be flexible enough to adapt to any momentary system conditions. Like the growth of population, the demand for electricity is also tremendously increases day to day. So there may be a need to enhance either the existing power system or establish the new system to supply the power to meet the particular load demands. The establishment of new power system is very costliest choice. So we mostly concentrate on the first choice that is enhancing the existing power system .The issue of transmission overloading is more pronounced in power systems due to the lack of coordination in between generation and transmission utilities and needs a special treatment to relieve the overloading, so that the system is maintained in secure state[1-5]. Congestion management are mainly two types of techniques which are we consider FACTS devices[5-8].

The operation of an ac power transmission line, is generally constrained by limitations of one or more network parameters and operating variables by using FACTS technology such as Thyristor Controlled Series Capacitor (TCSC)[8-12]. Because of the Economic considerations, Installation of facts Controllers in all the buses or lines is impossible and Unnecessary. There are several methods for finding the

optimal location of FACTS devices in a power system. In sensitivity approach[12-15] is used to find the optimal location for placement of TCSC.The reduction of total system reactive Power loss method is one used to find optimal location for placement of series FACTS device. In series FACTS devices like TCSC are considered one such technology that reduced the transmission overloading, power loss (active, reactive) and allows better utilization of existing grid infrastructure, along with many benefits[15-16].

This paper presents a new method for optimal location of series FACTS Controllers for congestion management in the power systems. The organization of this paper is a follows. Section 2 presents the Thyristor Controlled Series Capacitor (TCSC). Section 3 Optimal placement of TCSC using loss sensitivity index method. Section 4 Criteria for Optimal placement for TCSC to relive the congestion in power system. Section 5 presents the results of the simulations conducted using the proposed IEEE-14 bus system. Finally Section 6 presents the conclusion

2.THYRISTOR CONTROLLED SERIES CAPACITOR (TCSC)

TCSC is thyristor based FACTS controlled .The basic Thyristor Controlled Series Capacitor scheme, proposed in 1986 by Vithayathil is shown in figure 1. It consists of the series compensating capacitor shunted by a Thyristor-controlled Reactor in order to provide a smoothly variable series capacitive reactance. A variable reactor such as Thyristor Controlled Reactor (TCR) is connected across a series capacitor. In a practical TCSC implementation, several such basic compensators may be connected in series to obtain the desired voltage rating and operating characteristics. The effect of TCSC on network can be seen as a controllable reactance inserted in the related transmission line that compensates for the inductive reactance of the line. This reduces the transfer reactance between the buses to which the TCSC is connected. Hence power transferred is increased.

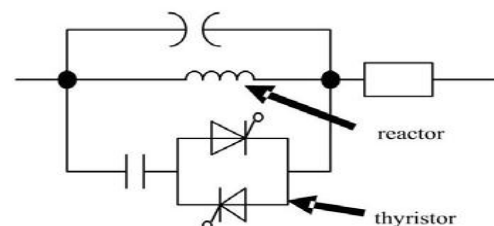

Fig 1. Equivalent circuit of TCSC
Although FACTS controllers are utilized in the system to

perform their primary task of stability control, they also improve the steady state performance of the system. The present work has only considered their impact on the congestion management, formulated as a steady state problem.

2.1 Transmission line modeling with TCSC

The series impedance of a high voltage transmission line is usually inductive, with only 5 to 10 percentage of resistance this provides convenient condition to control the steady state impedance of transmission line by adding both a Thyristor Controlled Series Capacitor (TCSC) and a Thyristor Controlled series Reactor

A General equivalent circuit of TCSC injected in transmission line is shown in fig2.

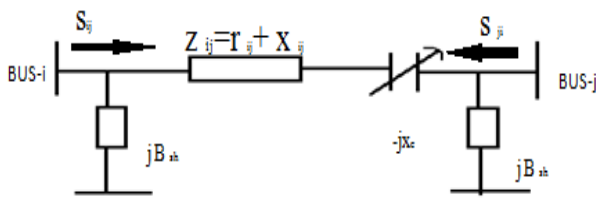

Fig 2. Injection Model of TCSC

Let the complex voltage at bus i and bus j be denoted as $V_i \angle \delta_i$ and $V_j \angle \delta_j$ respectively. The expression for real and reactive power flows from bus i and j can be written as follows

$$P_{ij}^c = V_i^2 \Delta G_{ij} - V_i V_j (\Delta G_{ij} \cos \delta_{ij} + \Delta B_{ij} \sin \delta_{ij}) \quad (1)$$

$$Q_{ij}^c = -V_i^2 (\Delta B_{ij}^j + B_{ij}^j) - V_i V_j (\Delta G_{ij} \sin \delta_{ij} + \Delta B_{ij}^i \cos \delta_{ij}) \quad (2)$$

Similarly, the real and reactive power flows from bus i to bus j can be expressed.

$$P_{ic} = V_i^2 \Delta G_{ij} - V_i V_j (\Delta G_{ij} \cos \delta_{ij} + \Delta B_{ij} \sin \delta_{ij}) \quad (3)$$

$$P_{jc} = V_j^2 \Delta G_{ij} - V_i V_j (\Delta G_{ij} \cos \delta_{ij} + \Delta B_{ij} \sin \delta_{ij}) \quad (4)$$

$$Q_{ic}^j = -V_i^2 \Delta B_{ij}^j - V_i V_j (\Delta G_{ij} \sin \delta_{ij} - \Delta B_{ij}^i \cos \delta_{ij}) \quad (5)$$

$$Q_{jc}^i = -V_j^2 \Delta B_{ij}^i + V_i V_j (\Delta G_{ij} \sin \delta_{ij} + \Delta B_{ij}^j \cos \delta_{ij}) \quad (6)$$

3. OPTIMAL PLACEMENT OF TCSC USING LOSS SENSITIVITY INDEX METHOD

Based on sensitivity approach, we find the optimal location of TCSC for congestion management. The static conditions are considering here for the placement of FACTS devices in the power system. The objective of the loss Sensitivity index may be one of the following:

1. Reduction in the real power loss of a particular line,
2. Reduction in the total system real power loss,
3. Reduction in the total reactive power loss
4. Reduction in the overloading of the system.

Loss sensitivity index is method based on the sensitivity of total system active and reactive power loss with respect to control variable of the FACT device.

The power loss sensitivity index with respect to this control variable can be formulated as

$$a_{ij} = \partial Q_L / \partial X_{ij} \quad (7)$$

Loss sensitivity with respect to TCSC

These factors can be computed for a base case power flow solution. Consider a line connected between buses i and j and having a net series impedance of X_{ij} , that includes the reactance of a TCSC, if present. The loss sensitivities with respect to X_{ij} can be computed as:

$$\frac{\partial Q_L}{\partial X_{ij}} = [v_i^2 + v_j^2 - 2v_i v_j \cos(\delta_i - \delta_j)] \frac{R_{ij}^2 - X_{ij}^2}{(R_{ij}^2 + X_{ij}^2)^2} \quad (8)$$

Where Q_L can be formulated as

$$Q_L = Q_{ij} + Q_{ji} = -V_i^2 (B_{ij} + B_{sh}) - V_j^2 (B_{ij} - B_{sh}) + 2V_i V_j B_{ij} \cos(\delta_i - \delta_j) \quad (9)$$

With the sensitivity indices computed for TCSC following criteria can be used for its optimal placement.

4. CRITERIA FOR OPTIMAL PLACEMENT FOR TCSC

The optimal location of FACTS devices is one of the important concepts. The main goal of the congestion management is to perform a best utilization of the existing transmission lines. The FACTS device should be placed on the most sensitivity bus or line. For the TCSC the location is the line with most positive sensitivity index. The TCSC should be placed on the line having most positive loss sensitivity index.

5. SIMULATION RESULTS

In this study the modified IEEE 14 bus system has been analyzed for congestion management by the optimal location of FACTS device such as TCSC using the MATLAB-SIMULINK. Fig 3 indicates the single line diagram of modified IEEE 14 bus system it consists of five generators, eleven loads and twenty lines. Construct modified IEEE 14 bus in Matlab-Simulink and run the simulation. By using TCSC, congestion is alleviated. For placing TCSC at optimal location we will use sensitivity analysis. The FACTS device placement method known as sensitivity index has been tested on IEEE 14- bus system.

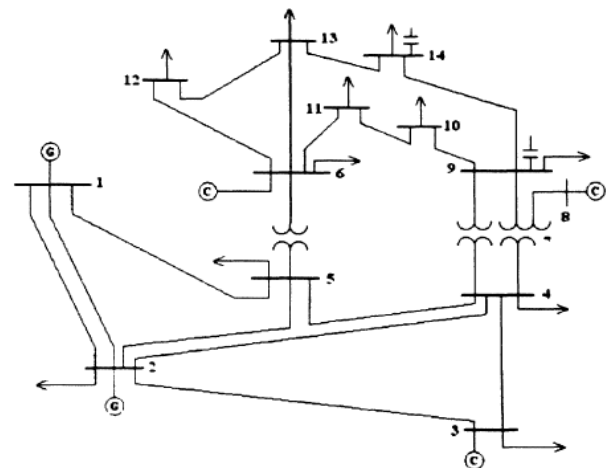

Fig 3. Shows the single line diagram of IEEE 14-bus System

5.1 Simulation results for modified IEEE 14-bus system without TCSC:

Test results are obtained by considering practical IEEE 14-bus system. Real and Reactive Power at bus 3 and bus2 as shown following graphs shown without any overloading.

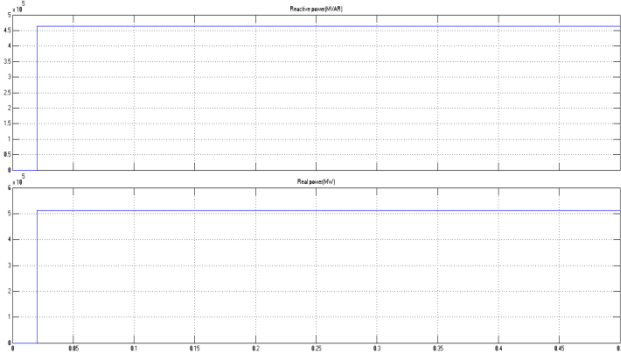

Fig 4 :Base case at BUS 2 Reactive and Real power without TCSC

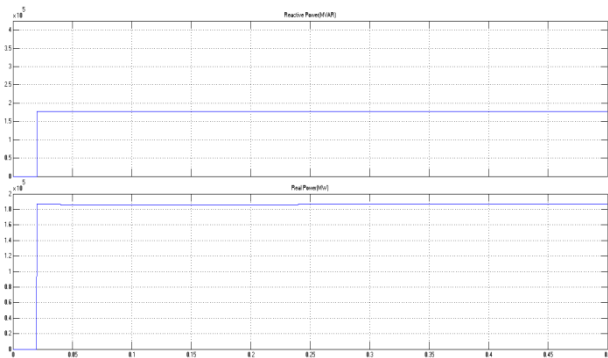

Fig 5:Base case at BUS 3 Reactive and Real power without TCSC

Power flow profile of the IEEE-14 bus system for different buses is presented below Table 1 without any over loading as presented below:

Bus No	Real power(MW)	Reactive power(MVAR)
1	0.0641	0.0581
2	0.5119	0.4632
3	1.872	1.778
8	0.2425	0.2486
9	0.246	0.4094
10	6.378	6.085
12	2.29	2.99
14	0.0981	0.0376

Table.1 Base case of Real and Reactive Power of IEEE-14 bus without TCSC

Congestion is created at bus 2 and bus 3 by increasing the load on particular bus then line at particular buses are

congested, the graphs shown the real and reactive power at bus3 and bus2 without any FACTS devices.

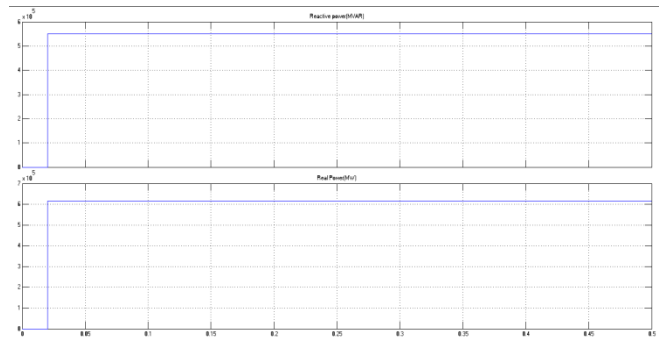

Fig 6: Over loading at BUS2 Reactive and Real power without TCSC

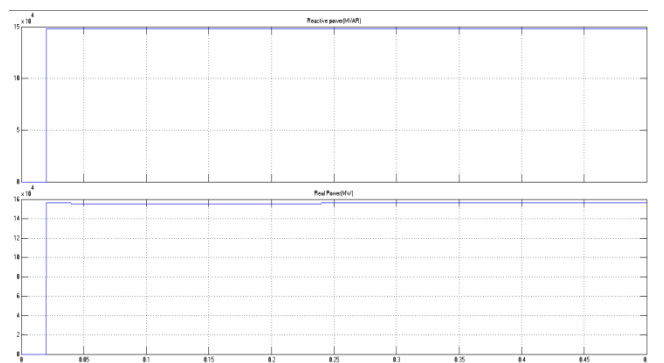

Fig 7: Over loading at BUS 3 Reactive and Real power without TCSC

Power flow profile of the IEEE-14 bus system for different buses is presented below Table 2 without incorporating the TCSC during overloading at bus 3.

Bus No	Real power(MW)	Reactive Power(MVAR)
1	0.06411	0.05816
2	0.6146	0.5511
3	0.1617	0.1703
8	0.2425	0.2487
9	0.246	0.4094
10	6.378	6.085
12	2.293	2.995
14	0.09814	0.03768

Table.2 Real and Reactive Power of IEEE14 bus overloading at Bus2 and Bus 3 without TCSC

5.2 Sensitivity approach

It is observed that the Bus 3 is congested/overloaded compared to other buses. Due to the increased loading at this bus system is congested. So by using TCSC, congestion is alleviated. For placing TCSC at optimal location we will use

sensitivity analysis. The sensitivity indices table of modified IEEE 14 bus system is shown in below.

Lines	From bus	To bus	Sensitivity index
1	1	2	-0.345
2	1	5	-0.456
3	2	3	-0.443
4	2	4	-0.231
5	2	5	-0.130
6	3	4	-0.042
7	4	5	-0.293
8	4	7	-0.196
9	4	9	-0.025
10	5	6	-0.213
11	6	11	-0.008
12	6	12	-0.005
13	6	13	-0.025
14	7	8	-0.037
15	7	9	-0.087
16	9	10	-0.0014
17	9	14	-0.0044
18	10	11	-0.0043
19	12	13	-0.00005
20	13	14	-0.0013

Table .3 Sensitivity index analyses

From Table: 3, the line 1-5 has the most positive sensitivity factor. So this is the best location for placement of Thyristor Controlled Switched Capacitor [TCSC] to relieve congestion in the network. By placing the TCSC in the line 1-5, the congestion in the network is relieved.

5.3 Simulation results on IEEE 14-bus system with TCSC

In this section IEEE 14 –bus practical system has been presented to numerically demonstrate its performance. It has been used to show quantitatively, how the TSCS performs. The original network is modified to include the TCSC. This compensates the line between any of the buses. The TCSC is used to regulate the Active and Reactive power flowing in the line at a prespecified value. The MATLAB-SIMULINK model is shown in fig4 it is used to find control settings of TCSC for the prespecified Real and Reactive power flow between any buses and the power flow between the lines are observed the effects of TCSC.

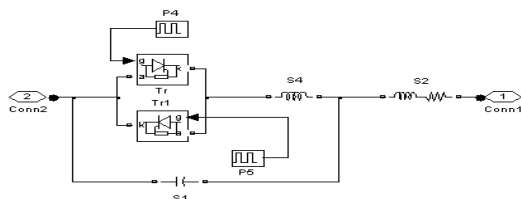

Fig 8: TCSC model in Matlab-Simulink

The FACTS device placement method known as sensitivity index has been tested on IEEE-14 bus system. After

incorporating TCSC the congestion in the network is relieved and the active reactive power flow is also improved which is shown below graphs.

5.3.1 Graphs for with incorporation of TCSC

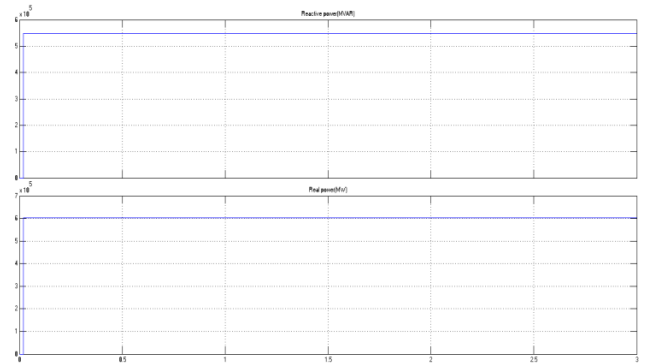

Fig 9: Bus 2 Reactive and Real power with TCSC

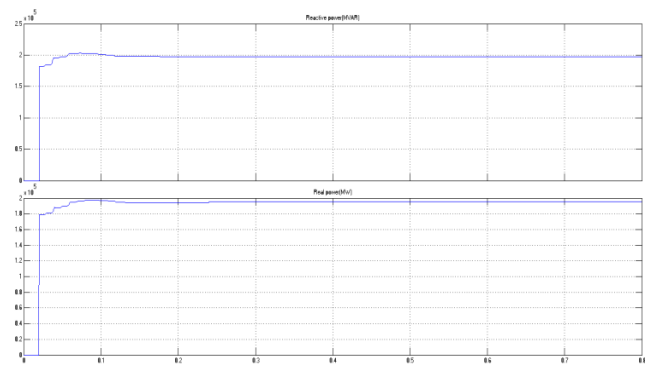

Fig 10: Bus 3 Reactive and Real power with TCSC

Power flow profile of the IEEE-14 bus system for different buses is presented below Table 4 with incorporating the TCSC during overloading at bus 3 and bus 2. Clearly observed congestion is relieved, active and reactive power flow is also improved.

Bus NO	Real Power(MW)	Reactive power(MVAR)
1	0.0678	0.0625
2	0.6019	0.5474
3	0.1977	0.1954
8	0.2612	0.2581
9	0.249	0.4156
10	6.455	6.16
12	2.291	2.994
14	0.0981	0.0376

Table:4 Real and Reactive power at each Bus with TCSC

The different loading conditions at bus 3 are shown below Table5 and observe the real and reactive power flows with and without incorporating the TCSC device.

Percentage of loading at bus 3	Without TCSC		With TCSC	
	Real power (MW)	Reactive power (MVAR)	Real power (MW)	Reactive power (MVAR)
110%	0.1705	0.1617	0.1954	0.1977
115%	0.1619	0.1546	0.1872	0.1892
120%	0.1564	0.1482	0.1796	0.1817

Table.5 Real and Reactive power at different loading conditions with and without TCSC

The comparison of Active and Reactive power flows of modified IEEE 14 bus system with and without TCSC during congestion as shown in below charts.

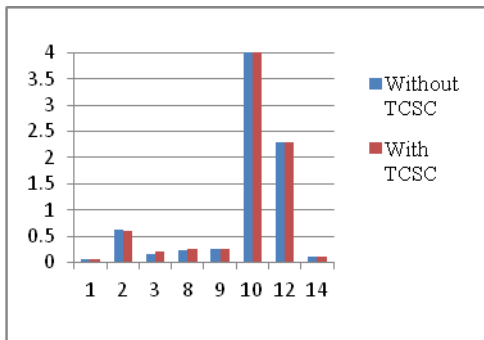

Chart 1: compression of Real power (MW)

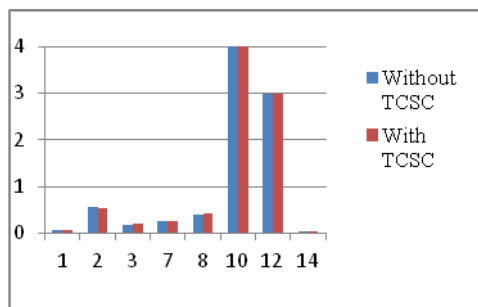

Chart 2: compression of Reactive power (MVAR)

6. CONCLUSION

In the transmission power system, congestion management is the quite critical task. This paper presents the congestion management using series FACTS devices to predict the optimal location for placement of series FACTS devices such as TCSC to relieve the congestion in power system. Based on the total system VAR power loss sensitivity methods we found optimal location for placing of TCSC to manage the congestion. This method gave the line has the most positive

sensitivity factor it is the best location of placement of TCSC to relieve congestion in the network. These proposed methods were successfully tested on modified IEEE 14 bus system and observe results with and without FACTS devices. So, it can be concluded that after placing the TCSC device by controlling the power flow in the network can help to reduce flows in overloaded lines and power flow in the power system network can be improved.

REFERENCES

- [1] Srinivasa Rao Pudi, S.C. Srivastava "optimal placement of tcsc based on a sensitivity approach for congestion management" Fifteenth National Power Systems Conference (NPSC), IIT Bombay, December 2008.
- [2] Keshi Reddy, Saidi Reddy1, Narayana Prasad Padhy, and R. N. Patel "congestion management in deregulated power system using facts devices" 0-7803-9525- 5/06 /\$20.00 ©2006 IEEE.
- [3] Rahul Dubey, Shishir Dixit, Ganga Agnihotri "Optimal Placement of Shunt FACTS Devices Using Heuristic Optimization Techniques: An Overview" 2014 Fourth International Conference on Communication Systems and Network Technologies 978-1-4799-3070-8/14 \$31.00 © 2014 IEEE.
- [4] A.K.M. Rezwannur Rahman, Md. Shahabul Alam, Md. Zakir Hossain and Md. Shahjahan "Localization of FACTS Devices for Optimal Power Flow Using Genetic Algorithm" 2013 International Conference on Electrical Information and Communication Technology (EICT).
- [5] Guguloth Ramesh, T. K. Sunil Kumar "Congestion Management in a Deregulated Power System with Micro Grid" World Academy of Science, Engineering and Technology International Journal of Electrical, Robotics, Electronics and Communications Engineering Vol:7 No:11, 2013.
- [6] Nazanin Hosseinipoor, Syed M.H Nabavi "Optimal Locating and Sizing of TCSC Using Genetic Algorithm for Congestion Management in Deregulated Power Markets".
- [7] M. Joorabian, M. Saniei, H. Sepahvand "Optimal Locating and Sizing of TCPST for Congestion Management in Deregulated Electricity Markets" UPEC 2011 · 46th International Universities' Power Engineering Conference · 5-8th September 2011 · Soest · Germany
- [8] N.Sambasiva Rao, Dr. J. Amarnath, Dr V. Purnachandra Rao " Enhancement of Power flow in the Deregulated Power System using Multi Type FACTS Devices" 2014 INTERNATIONAL CONFERENCE ON COMPUTATION OF POWER, ENERGY, INFORMATION AND COMMUNICATION (ICCPEIC) 978-1-4799-3826-1/14/\$31.00©2014 IEEE.
- [9] Kennedy Mwanza, You Shi, Le Anh Tuan "Economic Evaluation of FACTS for Congestion Management in Pool Markets" 978-1-4244-2190-9/07/\$25.00 ©2007 IEEE.
- [10] J.Srinivasa Rao, Dr.J.Amarnath "Transmission Congestion Management Comparative Studies In Restructured Power System" International Journal of Scientific & Engineering Research, VoluOptimal Location ofTCSC using Hybrid DE/BBO Algorithm me 4, Issue 8, August-2013.
- [11] N.Ashok kumar, M.Rathinakumar, M.Yogesh, J.Dinesh "Comparative Study on the Effectiveness of TCSC and UPFC Facts Controllers "International Journal of Computer Applications (0975 – 8887) Volume 67– No.5, April 2013 .
- [12] K.Vijayakumar "Optimal Location of FACTS Devices for Congestion Management in Deregulated Power Systems "

International Journal of Computer Applications (0975 – 8887) Volume 16– No.6, February 2011.

- [13] Susanta Duttal, Provas Kumar RO “Optimal Location of TCSC using Hybrid DE/BBO Algorithm” Proceedings of 2014 1st International Conference on Non Conventional Energy (ICONCE 2014).
- [14] Vijayakumari krishnasamy,jegatheeasn “Optimal Location of Multiple TCSCs for Congestion Management“ 2013 IEEE 7th International Power Engineering and Optimization Conference (PEOCO2013), Langkawi, Malaysia. 3-4 June.
- [15] Liangzhong Yao, Phill Cartwright, Laurent Schmitt, Xiao-Ping Zhang “Congestion Management of Transmission Systems Using FACTS” 2005 IEEE/PES Transmission and Distribution Conference & Exhibition: Asia and Pacific Dalian, China.
- [16] M. Gitizadeh, and M. Kalantar “A New Approach for Congestion Management via Optimal Location of FACTS Devices in Deregulated Power Systems” DRPT2008 6-9 April 2008.

About Authors:



V.k.Deepthi is pursuing her M.Tech (Power System Automation and Control) in the Department of Electrical & Electronics Engineering, from P.V.P.Siddhartha Institute of Technology, Vijayawada, Andhra Pradesh, India. She obtained B.Tech degree in Electrical and Electronics Engineering from DVR & HS MIC college of Technology



Baddu Naik. B is currently working as Assistant Professor in the Department of Electrical & Electronics Engineering, P.V.P.Siddhartha Institute of Technology, Vijayawada, Andhra Pradesh, India. He obtained M.Tech. Degree in power system with High Voltage Engineering from the JNTU Kakinada and doing Ph.D in the area of power system Deregulation at JNTU Kakinada. His areas of interest are Power system deregulation, FACTS, power system protection.